

# USER MANUAL

---

## AN1404 4G Door Station (ACCESS CONTROL SYSTEM)

---



**For your protection, read these instructions completely and  
keep them for future reference.**

**Distributed By:**

Aristel Networks Pty Ltd

Unit 1/25 Howleys Rd Notting Hill VIC 3168

Ph: (03) 8542 2300 Fax: (03) 9544 3299

[www.aristel.com.au](http://www.aristel.com.au)

# **TABLE OF CONTENTS**

<b>IMPORTANT SAFETY INSTRUCTION</b> .....	3
<b>AN1404 4G DOOR STATION INTRODUCTION</b> .....	4
<b>AN1404 4G DOOR STATION WITH ACCESSORIES</b> .....	4
<b>INSTALLATION</b> .....	5
AN1404 4G Door Station Unit Introduction.....	5
Wiring Diagram .....	7
LED Indicator .....	8
<b>AN1404 4G DOOR STATION OPERATION</b> .....	8
To Enter System Menu.....	9
Enter Listener Monitoring Mode .....	10
Enter Access Control Mode .....	10
Enter Programming Mode.....	10
Programming.....	11
Door/ Gate Release .....	13
Check 4G Signal Strength .....	14
Check Relay and Detect Status .....	14
Door Opening Detection .....	15
Panel Opening Detection.....	15
Administrator Number.....	15
Check a Log of Dial In and Dial Out Numbers Via E-Mail Or SMS.....	16
How to program checking the log of dial in numbers via SMS.....	17
<b>USER COMMANDS</b> .....	19
<b>HOW TO RESET THE HARDWARE WHEN YOU FORGET YOUR PASSWORD</b> .....	20
<b>SPECIFICATIONS</b> .....	21
<b>QUICK PROGRAMMING VIA SMS</b> .....	22

Thank you for purchasing AN1404 4G Door Station. Please read this manual carefully before using. Be sure to keep this manual for future reference.

## IMPORTANT SAFTY INSTRUCTIONS

When using this AN1404 4G Door Station, basic safety precautions should always be followed to reduce the risk of fire, electric shock and personal injury. Please read the following before using your equipment.

1. Follow all warning and instructions on the product.
2. Unplug all the connections of product before cleaning. Do not use liquid cleaners or aerosol cleaners. Use a damp cloth for cleaning.
3. Do not use this product near water.
4. Do not use this product near an area where there is a potential of gas leaks or near any fumes that can be explosive.
5. Do not place this equipment near or over a radiator or any other heat source.
6. Do not overload the wall outlet or power cord where the power adapter is installed. This can result in fire or electric shock
7. Avoid spilling liquid on this equipment and do not insert any objects through the ventilation slots.
8. Avoid using the equipment during an electrical storm. There is a remote risk of electrical shock from lighting.

## AN1404 3G DOOR PHONE INTRODUCTION

The 3G Door Station AN1404 is an intercom system and access control device which can be installed at the entrance of a building, gate fence or door. The device can operate on local 12-24volt AC or DC power. It enables you to speak with visitors from any location on or off the premises.

Door or gate release is activated from your phone keypad by pressing \* duration the conversation and can also be activated by calling the SIM card in the unit from an authorized phone number (guest). The door unit will recognize an authorized phone (guest) number calling it and will then not answer the call, but will release the door or gate. This call is free.

**Product main features:**

1. Stainless-Steel faceplate, Weatherproof.
2. Standalone and Vandal resistant design.
4. Calls up to 3 numbers in sequence.
5. Caller ID access by free call from an authorized phone number (guest).
6. Up to 48 guest numbers can be stored.
7. Can be used for silent monitoring.
8. Ring time/ call time/ relay activate time is adjustable.
9. Relay can be controlled to hold or release the gate.
10. Simple programming via SMS
11. Works with power supplies in the range 12~24V AC/DC.
12. Check dial in and out numbers log via SMS or E-mail
13. Works with mobile phones and land lines.

**AN1404 4G DOOR PHONE AND ACCESSORIES**

Item	Description	Q'ty	Included	Optional
1	AN1404 – 4G Door Station	1	√	
2	Power adapter	1	√	
3	Operational manual	1	√	
4	Surface mounting enclosure	1		√

# INSTALLATION

## AN1404 4G Door Station Layout

This 4G Door Station is suitable for both flush and surface mounting.

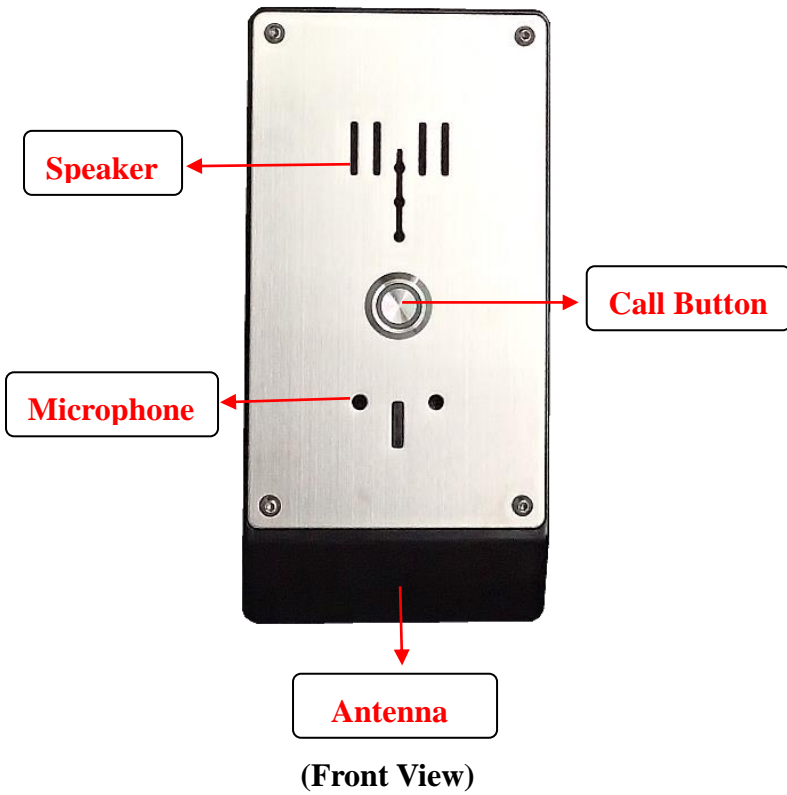

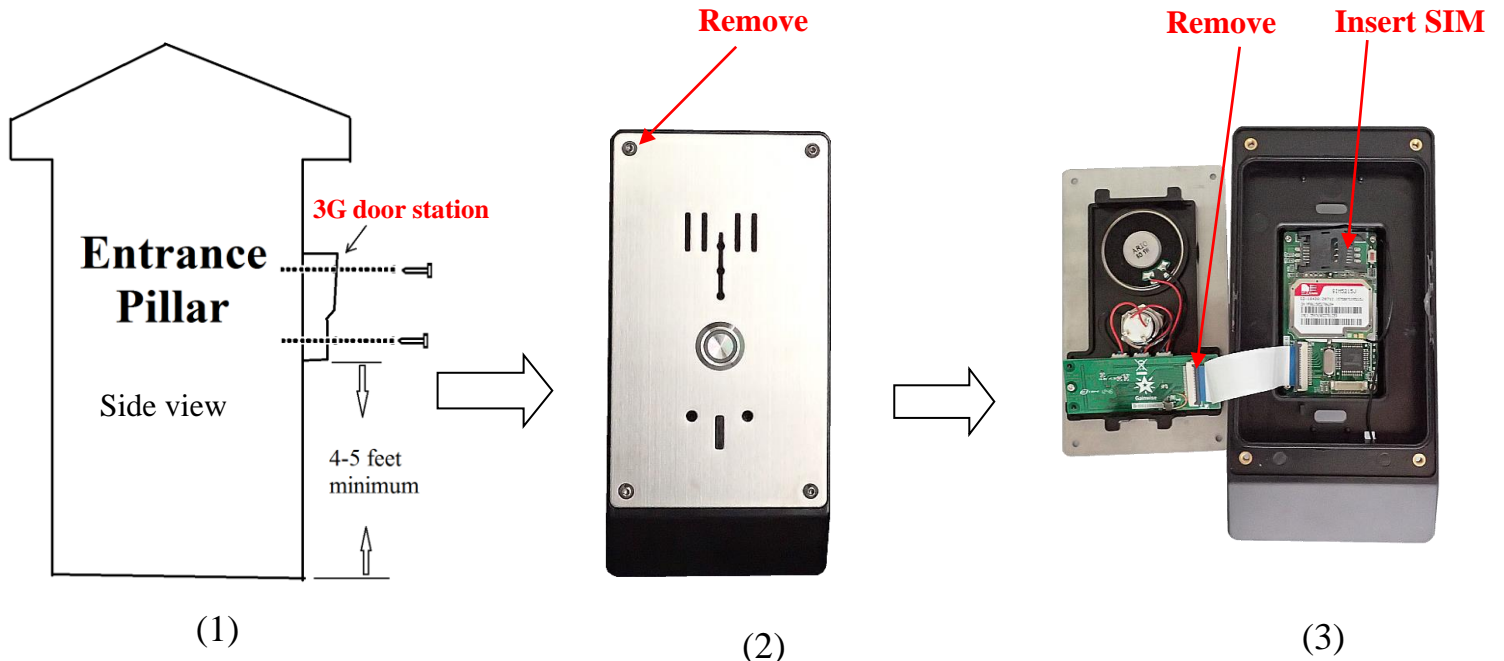

Screw



(4)

Connector



(5)

Screw



(6)

**Ensure that there is good network reception at the location where it will be installed**

Follow the instructions step by step for installation:

1. Install the surface mounting enclosure by using appropriate fixings on the entrance pillar at 150-160 mm height.
2. Remove security screws from the front panel.
3. Remove the flat cable from the back panel and insert the SIM card.
4. Put the main station unit into the enclosure and fasten it with screws on top and bottom.
5. Connecting the flat cable (**BLUE** side face up) back to the back panel
6. Fasten the front panel with security screws

## Wiring Diagram

Please follow the wiring instructions carefully.

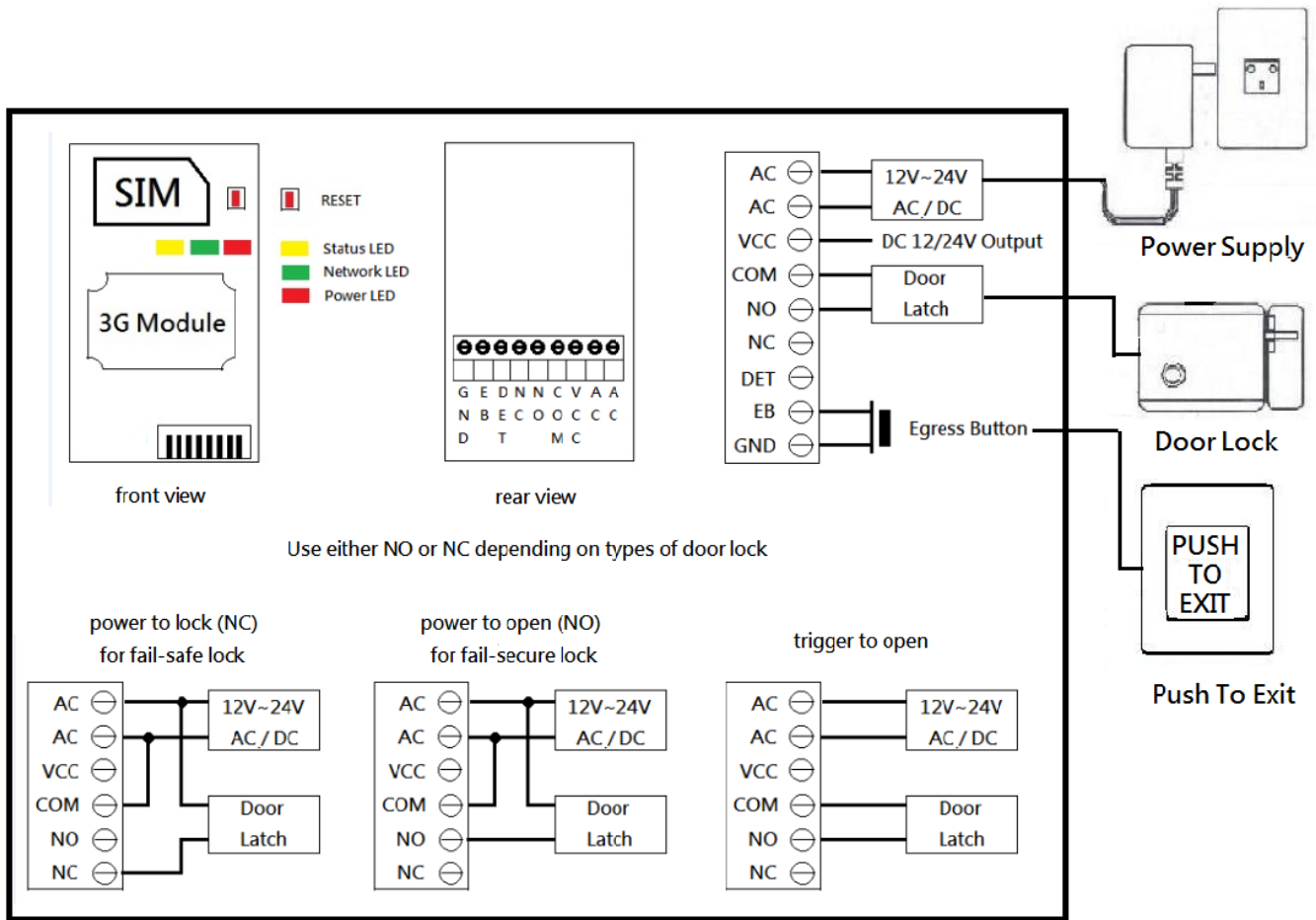

### 1. SIM card

Register your SIM card with the network, and check it works in a mobile phone

You MUST remove the PIN code from the SIM before inserting it in the AN1404.

Ensure the power is OFF before inserting the SIM card. Carefully slide the SIM holder in the OPEN direction, insert the SIM, and slide in the CLOSED direction to lock it in place.

### 2. Door Lock

Connect an electric door lock to terminals marked “NO or NC & COM as required.

### 3. Power Supply

- Connect a 12 volt DC power supply to terminals marked “AC, AC”.
- The power supply should be capable of supplying a constant current of no less than 1amp.
- Alternatively, you may use local 12-24 DC or AC power source.

### 4. After a final check of wiring, switch on the power.

### 5. Allow 20~30 seconds for the unit to boot up and detect the network. Once a successful connection has been made, the unit will sound a confirmation tone and the status LED will begin flashing.

## LED Indicators

(Also see wiring diagram)

### 1. LED “Door Station Status “ Indicator

LED	Status
Yellow (standby)	0.1sec ON / 2 sec OFF
Yellow (using)	Solid

### 2. LED ‘Network “Indicator

LED	Status
Green (ready)	1 sec ON/ 1 sec OFF
Green (searching)	Solid
Green (busy)	Solid

### 3. LED “ Power “ Indicator

LED	Status
Red (power on)	Solid
Red (power off)	Off

## AN1404 4G Door Station Operation

When the visitor pushes the call button to activate 4G door station, a ring tone will be heard from the Door Station. At the same time, a connection is being established with the phone number that is stored in the door station. If the first number is busy or has not answered the call can be diverted to another phone number, (mobile or landline). When the remote phone answers the call from the door station and converses with the visitor, the door or gate release can be activated by pressing \* on the phone’s keypad. Relay can also be temporarily or permanently switched on or off by pressing # and 1.

### To enter system menu:

There are three different modes under the system menu.

1. Monitoring mode ( listening)
2. Access control mode
3. Programming mode

To gain access to the system menu via phone follows these steps:

1. Call the telephone number of the Door Station
2. Wait for the door station to answer and signal by one beep to enter system menu
3. Enter the password of the mode you require.
4. Password correct is one beep, password error is 3 beeps.
5. After 3 failed attempts at the password, the call hangs up.



## System flow Chart

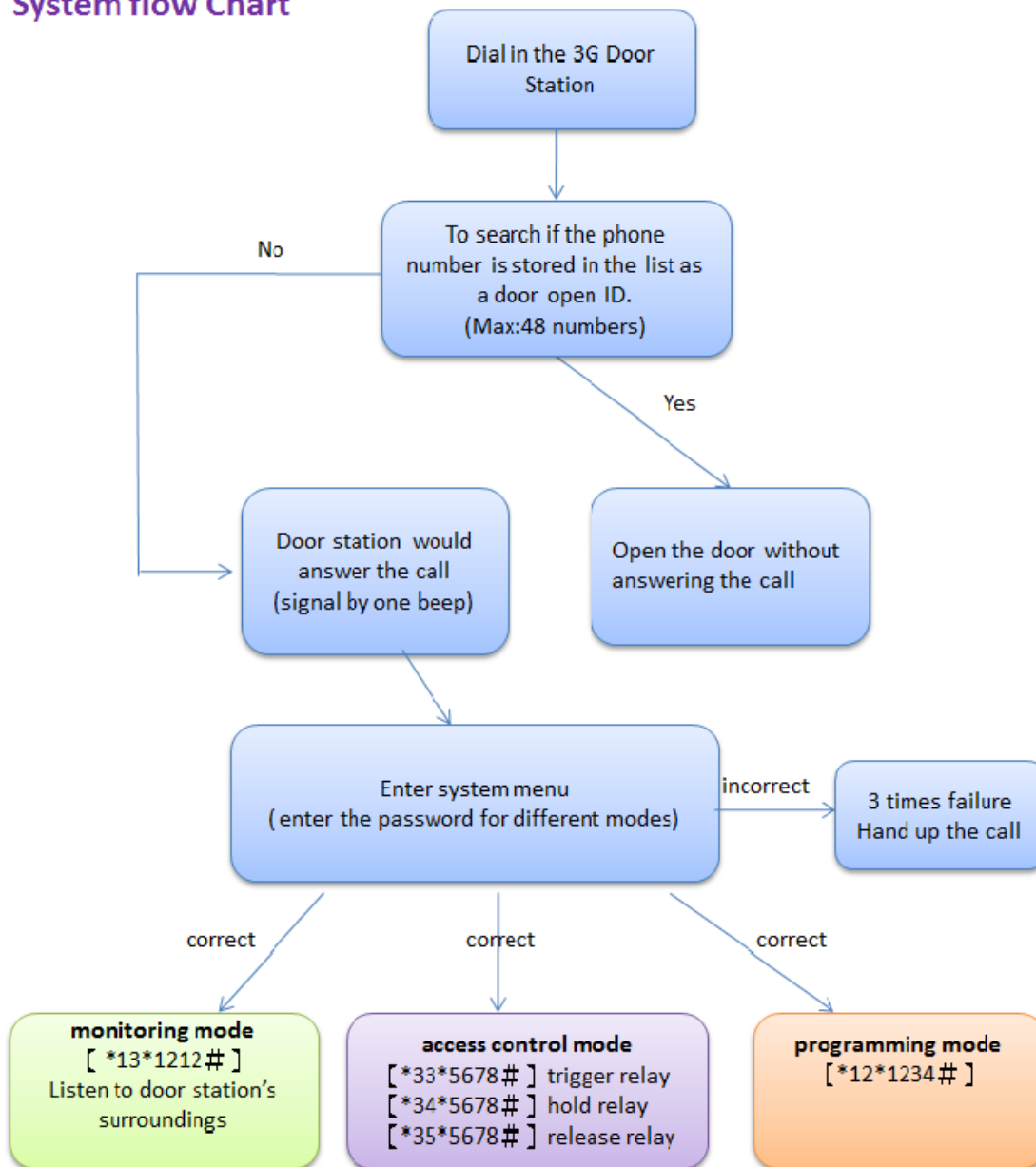

### Enter Monitoring Mode (listening)

1. Call the telephone number of the 3G door station
2. This device will then verify your phone number with your predefined numbers.
3. You will hear a “Do” tone to enter motoring mode by pressing **[\*13\*1212#]** where 1212 is the password. Then you will be able to listen to door station.

\* This feature can also be carried out by sending the same SMS commands

\* Under the monitoring mode speaker is OFF. (Press **35#** to **turn on** speaker)

\* You can still press \* to active relay under this mode but speaker must be ON status.

## Enter Access Control Mode

1. Call the telephone number of the door station.
2. This device will then verify your phone number with your predefined numbers.
3. You will hear a “Do” tone to enter access control mode by pressing **【\*33\*5678 #】** where 5678 is the password.
4. The door will be opened after entering the correct password

\*(To open the door by using password, if the number is not stored in the guest list)

## Enter Programming Mode

1. Call the telephone number of the door station
2. This device will then verify your phone number with your predefined numbers.
3. You will hear a “Do” tone to enter into programming mode by pressing **【\*12\* 1234 #】** where 1234 is the password.
4. You are now in the “programming mode”

**Note: At the end of each command there can be one of the two indications:**

**Successful: is a long “beep” tone, failed: are three short “beep” tones.**

5. To make changes on settings please refer to the user commands.
6. To end programming mode just hang up.

NOTE:

**\*For less chance of interference during programming, originate the call from a land line, rather than a mobile, and enter the digits slowly or using programming by text message.**

## Programming by text message

Programming can be carried out by phone or text message

(Certain programming features can only be set up by text message, refer to user commands)

Programming by text message is the simplest way to customize the settings of the Door Station and to add or delete guest telephone numbers. Simply send texts in the format to the telephone number of the SIM within the 4G Door Station.

**Note:**

1. A Single SMS text messages is limited to 140 characters.
2. You can program many different user command codes in one text message with SMS command format. **\*12\*1234 # [command Code1] # [command Code 2] # [command Code3] #.....**
3. Each SMS must start with the pass code , default 1234 in the following format **\*12\*1234 #** Followed immediately by a command.

- To program a call button numbers DO NOT enter country code, just the complete number as you would dial it.

**Example:**

Program call button phone numbers (Max 3 numbers) and delete 2&3 phone numbers.(Refer to user commands P.16)

058 57235 (landline number 1)

086 5682554 (mobile number 2)

086 2235644 (mobile number 3)

**Command to use: \*12\*1234#1[Y][X][ phone number] #....**

Y= 1~3 (sequence of phone number)

X= 1 (to receive audio call)

SMS format: (storing call button phone numbers)

\*12\*1234#11105857235#1210865682554#1310862235644#

SMS format: (delete 2&3 phone numbers from call button)

\*12\*1234#12\*#13\*#

**User command code CORRECT example:**

SMS format:

\*12\*1234#11105857235#1220865682554#1310862235644#

SMS reply:

11105857235#1220865682554#1310862235644# OK

**User command code ERROR (user command 129 error) example:**

SMS format:

\*12\*1234#11105857235#1290865682554#1310862235644#

SMS reply:

11105857235#1290865682554# Error

**Programming by phone:**

Note: Phone programming can't be used from phone numbers which are already programmed to open the door, but you can disable Caller ID display (withhold the number) on the mobile before using to bypass. (Prefix the number with 1831)

To gain access to the programming mode via phone follows these steps:

**Example:**

To program a telephone number for door release by phone

Enter Programming Mode by Pressing.....

\*12\***1234**# (1234 is default password)

A successful pass code will produce a single long beep. A failed attempt will produce 3 short beeps.

You may now program up to 48 telephone entry numbers into memory.

Use the following commands to program the unit

- \* Insert international country code (1~3 digits): **71 [country code] #**
- \* Add a number (up to 48 numbers): **72 [ telephone number] #**
- \* Delete a number: **73 [ telephone number] #**
- \* Delete all numbers: **73\*#**

**Door /Gate Release**

This 4G Door Station also has an extra feature to allow user to gain access from their phone by two methods.

1. by Caller ID recognition
2. by access control password mode

**1. Caller ID recognition to open**

Ring in to open the door for authorized telephone numbers. It can support for up to 48 users.

When the Door Station receives an incoming call from, it will check the calling number and if the number is in the guest list, the Door Station will drop the call and then open the gate / door. The Door Station doesn't answer the call, it simply checks the caller ID, so this is a free call.

**For Caller ID recognition to open the door or gate you need to program the COUNTRY CODE and mobile numbers into the memory before using.**

**Example:**

Ireland Country code: 353 (UK: 44 / USA: 1)

086 5683624 (1. mobile number)

086 5682554 (2. mobile number)

086 2235644 (3. mobile number)

**Command to use: \*12\*1234#71[country code]#72[ phone number] #72[ phone number] #....**

SMS format:

\*12\*1234#71353#720865683624#720865682554#720862235644#

### **To delete phone numbers of dialing in to open**

SMS format: (to delete phone number 1 and 2)

\*12\*1234#730865683624#730865682554#

SMS format: (to delete all numbers)

\*12\*1234#73\*#

After the numbers are programmed you can send a text message to check the stored numbers by sending SMS format \*21# , then the Door Station will reply with the phone number list text message.

## **2. Access control password to open**

Dial the SIM card telephone number. The unit will answer the call and you will hear a bleep tone.

To trigger door by pressing \*33\*5678#

To latch or hold open door by pressing \*34\*5678#

To unlatch door by pressing \*35\*5678#

\*This feature can also be carried out by sending the same SMS commands.

## **TO CHECK SIGNAL STRENGTH: (0~31 LEVELS)**

When a request for signal strength SMS is sent to the 3G Door Station it will reply with a signal strength code, service provider name and current network (GSM or WCDMA).The signal strength code will be between 0~31 means the signal level is from poor to best. When the unit detects the WCDMA network signal is poor will automatically switch to GSM to get better signal.

Example

SMS format: \*20#

SMS reply: Vodafone , WCDMA, Signal Level = 31 【Signal is very strong】

## CHECK RELAY & DETECT (INPUT) STATUS:

You can send SMS command code to check relay status and Detect status.( checking door is opened or closed)

SMS format: \*22#

SMS reply: Relay=ON Detect = ON 【Relay=Hold, Detect=GND】

### Door opening detection

Terminal mark” DET” input” (see wiring diagram P7) is for you to connect a door sensor. The gate would have a sensor wired through “DET” input to ground. When the door sensor is triggered, a SMS message “**door open alarm**” will be sent to the predefined call button phone numbers.

### Panel opening detection – tamper alarm.

A panel opening sensor is built inside the electronic board, once the panel of Door Station has been removed, the alarm will go off from the speaker and a SMS message “**panel open alarm**” is sent to the predefined call button phone numbers.

### Administrator Number

Once the administrator’s number is stored in the unit, this is the only number that is allowed to enter the program mode, either by dialing in, or by text messages.

Example:

Program a mobile number as an administrator number via SMS

Mobile number: 0865682554

Command to use \*12\*1234#74 [Admin number]#

SMS format \*12\*1234#740865682554#

To delete the Admin number \*12\*1234#74\*#

## Check a Log of Dial in and Dial out Numbers via E-mail or SMS

This system allows you to save dial in numbers log and will then automatically send the record via e-mail or SMS as your request when it reaches 25 numbers in the memory.

There is a list of commands you need and examples to guide you on the settings for this feature. Please setup following required parameters and commands before you can use it.

**NOTE:** G-mail doesn't support this feature.

No.	Function	SMS command codes
1	Way of sending a log of dial in numbers via e-mail or SMS	*12*1234#84[N]# N=0 (no saving / no sending record) N=1 (via SMS, 4 numbers limited /SMS) N=2 (via e-mail, 25 numbers /e-mail )
Sending record via email / command code example: *12*1234#842#		
2	GPRS parameters setting	*40*1234#APN, auth_type,user name,paANword# auth_type: 0= none / 1= PAP / 2= CHAP
Command code <u>*40*1234#internet,0,,#</u> (auth_type = 0 (no need for user name and password)) Example: <u>pass code</u> <u>APN</u> <u>auth_type =0 (none)</u>		
3	E-mail parameters setting ( Doesn't support Gmail)	*41*1234#SMTP server,port,user name, paANword, e-mail addreAN, e-mail sender name#
Command code <u>*41*1234#gainwise.com,25, SS1404,5826, SS1404@gainwise.com,3G door station#</u> Example : <u>pass code</u> <u>SMTP server</u> <u>Port</u> <u>user name</u> <u>PD</u> <u>email address</u> <u>sender name</u>		
4	Recipient & Carbon copy settings	*42*1234# recipient e-mail addreAN, recipient name, carbon copy e-mail addreAN, carbon copy name#

Commande code example:

\*42\*1234#michael@gainwise.com,MICHAEL,ivy@gainwise.com,IVY# (complete setting)  
 pass code recipient email address recipient name carbon copy email address carbon copy name

\*42\*1234#michael@gainwise.com,ivy@gainwise.com,# (recipient/carbon copy name can be omitted)  
 pass code recipient email address carbon copy email address

\*42\*1234#michael@gainwise.com,MICHAEL,# (carbon copy can be omitted)  
 pass code recipient email address recipient name

5	E-mail subject setting	*43*1234# e-mail subject#
---	------------------------	---------------------------

Command code Example: \*43\*1234# dial in numbers log#  
 pass code email subject

No.	Function	SMS command codes
6	To immediately send current dial in numbers log via email or SMS	*44*1234#
7	Check parameters setting	*4[N]*1234# N=0 ( reply GPRS parameters) N=1 ( reply e-mail parameters) N=2 ( reply recipient & carbon copy) N=3 ( reply e-mail subject)
Check GPRS parameters setting / Command code example: *40*1234#		
8	Mobile number for receiving a log of dial in numbers via SMS	*12*1234#85[mobile Number]#
9	Delete mobile number for receiving a log of dial in numbers via SMS	*12*1234#85*#
10	SIM phone number used in door station for Clock date and time correction	*12*1234#86[SIM phone number used in door station]#
11	To delete SIM phone number used in door station for Clock date and time correction	*12*1234#86*#

**Note: why you need to setup the phone number for system time and date calibration?**

This device has a time clock and supports automatically updating their date and time via NITZ information from network. In case some of the networks are not available for NITZ information that we strongly suggest to setup date and time calibration. When the device detects NITZ information is not available from the network will automatically send a command to itself via the SIM card used in the



door station for time calibration which will keep your “ **dial in numbers log**” with correct date and time.

Log example:

```
001@13/02/23,13:16:31- I 0982384664
002@13/02/23,13:16:43- I 0982384663
003@13/02/23,13:16:53- O 0982437053
004@13/02/23,13:17:14- O 0926251767
005@13/02/23,13:17:46- I 0982384663
006@13/02/23,13:17:59- I 0982384664
007@13/02/23,13:18:06- O 0926251767
008@13/02/23,13:18:25- O 0982437053
```

N0.      date      time      |      phone number  
status

I : dial in number / O: dial out number

### How to program checking the log of dial in numbers via SMS

There are 3 programming codes you will need to make this feature work

1	Way of sending a log of dial in numbers via e-mail or SMS↵	*12*1234#84[N]# N=0 (no saving /sending record) N=1 (via SMS, 4 numbers limited /SMS) N=2 (via E-mail)↵
2	Mobile number for receiving a log of dial in numbers via SMS↵	*12*1234#85[mobile Number]#↵
3	SIM phone number used in door station for clock date and time correction	*12*1234#86[ SIM phone number used in door station ]#

You can program many different user command codes in a single text message with SMS command format. \*12\*1234 # [command Code1] # [command Code 2] # [command Code3] #.....

**Example:**

Mobile number for receiving a log 0907967223

SIM phone number used in the 3G door station 0948778458

\*12\*1234#841#850907967223#860948778458#

Send \*44\*1234# to check log

Replied log information via SMS example:

001@13/02/23,13:16:31- I 0982384664  
 002@13/02/23,13:16:43- I 0982384663  
 003@13/02/23,13:16:53- I 0982437053  
 004@13/02/23,13:17:14- I 0926251767 N or E

**I:** Dial IN numbers  
**N:**Next text message  
**E:** End text message

## User Commands

### To gain access to the different modes and control relay (via dial in)

No.	Function	Command	Description	Default
1	Enter Programming Mode	*12* [ password ] #	To enter system for programming	1234
2	Enter Monitoring Mode	*13* [ password ] #	To hear the surroundings where the 3G door station is installed	1212
3	Enter Access control Mode (Trigger relay)	*33* [ password ] #	Access control password mode	5678
4	Hold Relay	*34* [ password ] #	To hold relay to keep door opened	5678
5	Release Relay	*35* [ password ] #	To release relay for door close	5678

### User commands to check system info & control relay via SMS

No.	Function	Command	Reply
1	Check signal strength	*20#	Signal Level 0~31( from poor to best) Service provider name, network
2	Check stored numbers	*21#	O [ number]...I [ number]....E (N) O : call button numbers list I : dial in to open numbers list E : End N : Next SMS

3	Check relay status	*22#	Relay [status], Detect [status] Status= ON / OFF
4	Trigger relay	*33* [ password ] #	No reply (default paANword:5678) (Latch on when relay is on hold status)
5	Hold relay	*34* [ password ] #	No reply (default paANword:5678)
6	Release relay	*35* [ password ] #	No reply (default paANword:5678)
	• SMS data error	(Only 0~9 、 * 、 # are available)	SMS Data Error
	• Function code error		Function Code Error

### User commands table

You can program many different user command codes in one text meANage with SMS command format. \*12\*1234 # [command Code1] # [command Code 2] # [command Code3] #.....

No.	Feature	Command	Description	Default
1	Change password of Programming Mode	01 [new password] #	Password= 4 digit codes	1234
2	Change password of Access control Mode	02 [new password] #	Password= 4 digit codes	5678
3	Change password of Monitoring Mode	03 [new password] #	Password= 4 digit codes	1212
4	Store a call button phone number	1 [ Y][X][ phone number] #	Y=1~3 (sequence of phone number) X=1 (audio call) Max 3 phone numbers	None
5	Delete a call button Phone number	1 [Y] *#	Y=1~3 (sequence of phone number)	None
6	Speaker Volume	3 [ speaker volume] #	Volume= 0~4 levels	3
7	Microphone Volume	4 [ microphone volume] #	Volume= 0~4 levels	3
8	Relay Activate Time	51 [ relay activate time] #	Relay activate time= 1~9999 sec	1 sec
9	Divert to second no. time	52 [ divert time] #	divert time= 10~99 sec (2 digit codes)	20 sec
10	Call Time	53 [call time] #	call time= 005~999 sec (3 digit codes)	060 sec
11	Monitoring duration time	55 [time] #	Time= 00~60 minutes	10 mins

			00 ( no limit)	
12	Change trigger relay code	61 [ code ] #	code= 0,1,2,3,5,7,8,9 / * / #	*
13	Change hold relay code	63 [code ] #	code= 0,1,2,3,5,7,8,9 / * / #	#
14	Change release relay code	64 [ code ] #	code= 0,1,2,3,5,7,8,9 / * / #	1
15	Add ring tone after the phone is answered while waiting on making call	66 [ring tone ]#	Ring tone =0~9 tones	0
16	Ring in to open the door (Max: 48 numbers)	71 [ country code ] # 72 [ Add a phone number ] # 73 [ Del a phone number ] # 73*#	Country code =1~3 digit codes Add a number = 3~15 digit codes Del a number = 3~15 digit codes Del all phone numbers	886
17	Add administrator phone number	74 [ admin number] #	admin number= 3~15 digit codes ( no number no restriction)	None
18	Delete administrator phone number	74*#	delete administrator phone number	None

19	Door opening detection	81 [ X ] #	X= 0, 1 , 2 0: OFF / 1: GND 2: EOL (10Kohm)	Off
20	Panel opening alarm	82 [ X ] #	X= 1 , 2 1: alarm / 2: SMS & alarm	alarm
21	Reset	999#	reset default	None

## How To Reset The Hardware When You Forget your Password

### Warning :

For passwords, do not use two or more of the same number as successive digits .

EG. 11, 00, 112, 122, 88 are not recommended as echo cancellation network software may cancel the second same digit if entered quickly.

Use passwords like 89, 12 , 23 , 56, 14, 123, 369 , 789 etc without repeating the same digit numbers.

## Reset the hardware

- 1.first keep reset button (RED) pressed
- 2.then press engress button
- 3.release all buttons after you hearing continuous "Dou" tones
- 4.hardware reset finished

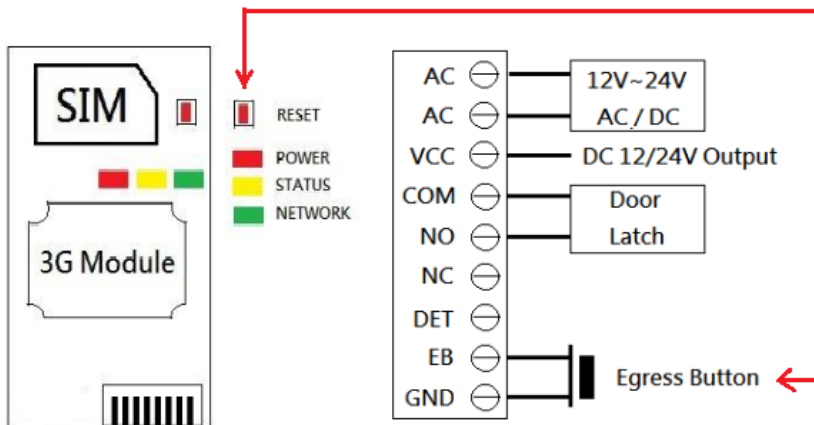

## AN1404 3G Door Station Specification

Model	AN1404 4G (4G B1/B2/B3/B4/B5/B7/B8/B28 3G B1/B5/B8)
Operating Voltage	12 ~ 24 Volt AC/DC
Operating Current	Maximum 250mA, Typically 55mA
Camera	CMOS camera module / 2 M pixels / lens angle 65.5°
Physical material	Stainless Steel and ABS
Physical size	164 x 81 x 20 mm
Weight	265g
Humidity	Less than 80% RH
Operating Temperature	-20°C to +50°C
Protection Index	IP 65

## Quick programming via SMS

Program a call button phone number. (Max 3 numbers)

To program call button numbers DO NOT enter country code, just the complete number as you would dial it.

### Example:

058 57235 (landline number 1)

086 5682554 (mobile number 2)

086 2235644 (mobile number 3)

**Command to use:** \*12\*1234#1[Y][X][ phone number] #....

Y= 1~3 (sequence of phone number)

X= 1 (to receive audio call)

SMS format: (storing call button phone numbers)

\*12\*1234#11105857235#1210865682554#1310862235644#

**Program a phone number for door release by phone (Max 48 numbers)**

Note: You NEED TO enter country code for this feature.

**Command to use:**

\*12\*1234#71[country code]#72[ phone number]#72[ phone number]#72[ phone number]#....

**Example:**

Ireland Country code: 353 (UK: 44 / USA: 1)

086 5683624 (mobile number 1)

086 5682554 (mobile number 2)

086 2235644 (mobile number 3)

SMS format: \*12\*1234#71353#720865683624#720865682554#720862235644#

**Operation**

When door station calling your phone and you have answered the call...

Press \* to open

Press # to hold open

Press 1 to release again.

Send SMS commands to have access control

SMS format:

\*33\*85678# (to open)

\*34\*85678# (to hold open)

\*35\*85678# (to release again)